

TOX[®]-Powerpackage Type X-KT-System

Data sheet 10.05
2022/05

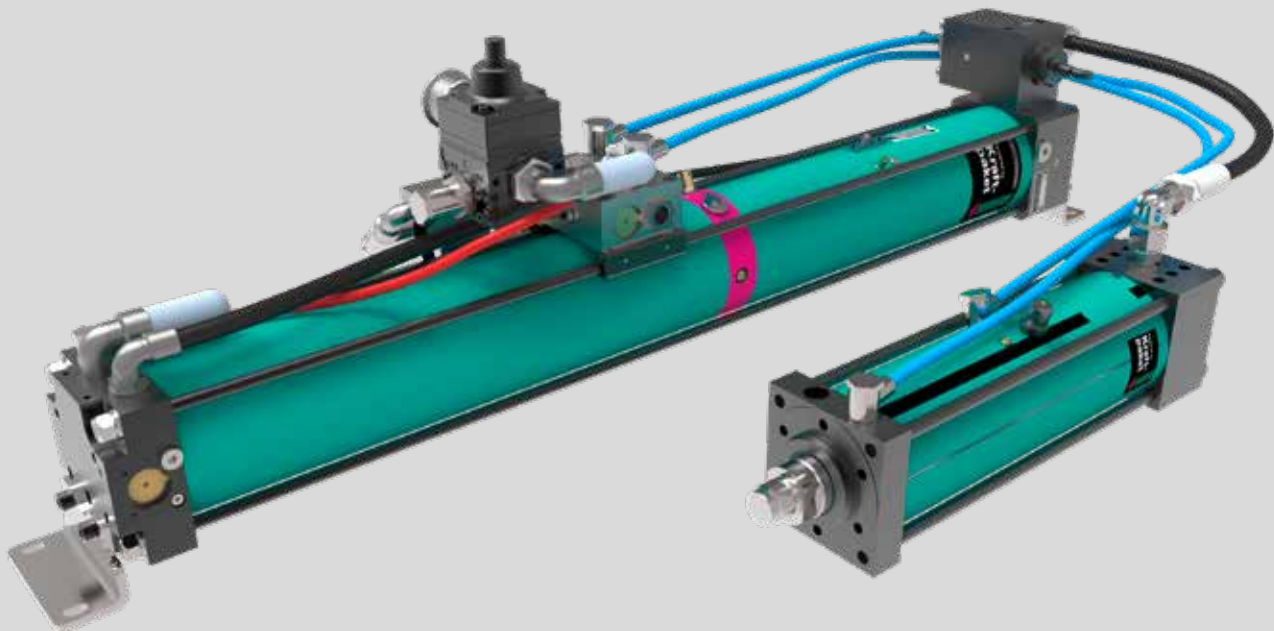

TOX®-Powerpackage X-KT-System

Customized to individual needs

The TOX®-Powerpackage X-KT-System consists of the pressure intensifier X-ES and one or more drive cylinders. Depending on the required press force, dimensions and cycle-time each system is configured individually to customer needs. Drive cylinders can be selected from either the TOX®-Hydraulic Cylinder HZL or the pneumohydraulic TOX®-Working Cylinder X-AT.

Advantages

- Press forces 2 – 1700 kN
- Long power strokes
- 10 million cycles within 12 months without work shift restrictions
- Compact measurements
- Easy controls
- Use up to 6 drive cylinders per intensifier
- Low noise
- Connection via TOX®-Hydrosplit Coupling
- Easy colour-guided pneumatic plug-in-system



Press with TOX®-Powerpackage X-KT-System:
1 pressure intensifier and 6 drive cylinders

TOX®-Pressure Intensifier X-ES with fast approach stroke function

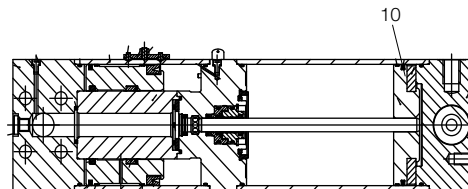
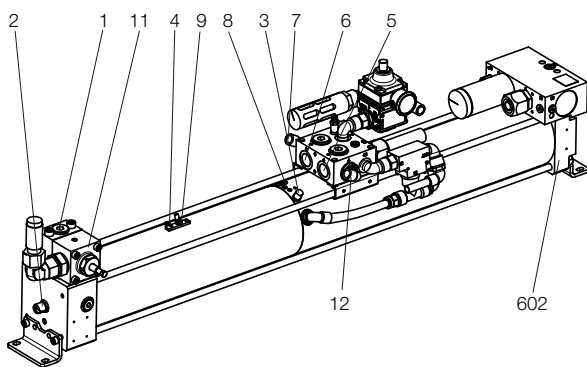

- | | |
|--|--|
| 1 High pressure connection | 8 Oil level indicator |
| 2 High pressure measuring and control connection | 9 Patented anti-overfill device |
| 3 Oil filling nipple | 10 Intensifier piston |
| 4 Bleed plate | 11 Hydrosplit coupling |
| 5 Air connection fast approach stroke | 12 Fast approach stroke hose (only for X-AT) |
| 6 Air connection return stroke | 602 Power stroke valve |
| 7 Return stroke air hose | |

The TOX®-Pressure Intensifier X-ES is connected to the drive cylinders via hydraulic hoses and TOX®-Hydrosplit Couplings. The changeover from fast approach stroke to power stroke is performed automatically according to the dynamic pressure principle. The speed of the changeover can be regulated via a control throttle. The unit is controlled by a 4/2 or 5/2-way valve.

As standard, the pressure intensifiers are designed for air pressure of 6 bar. Other air pressures or combinations on request.

The TOX®-Pressure Intensifier X-ES features:

- Absolute air-oil separation
- Integrated bypass for reliable operation of the system
- Ring reservoir for significantly reduced overall length
- Can be mounted in any orientation
- Air spring included
- Simple pneumatic controls like for any double acting pneumatic cylinder
- Closed oil system
- All X-KT-Systems with fast approach support

TOX[®]-Hydraulic Cylinder HZ

The TOX[®]-Hydraulic Cylinder HZL features an absolute air-oil separation. Fast approach stroke and return stroke are conducted by the pressure intensifier X-ES. That allows the return stroke to be operated with air pressure only (min. 3 bar).

Up to 6 TOX[®]-Hydraulic Cylinders HZL can be connected by default to one pressure intensifier (more on request).

Advantages

- Compact design
- Single-bearing working piston
- Absolute air-oil separation
- Fixed stop in approach stroke (elastomer cushioning optional)
- Options: stroke monitoring ZHU and travel transducer ZKW
- Budget solution
- Also available with total stroke adjustment (version 151)

See pages 5 – 9

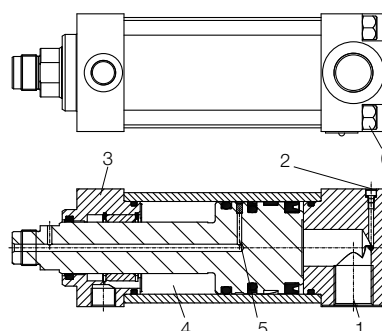

- | | |
|----------------------------|-------------------------------|
| 1 High pressure connection | 4 Return stroke chamber |
| 2 Bleed screw | 5 Absolute air-oil separation |
| 3 Special guiding system | 6 Flexible tie rod |

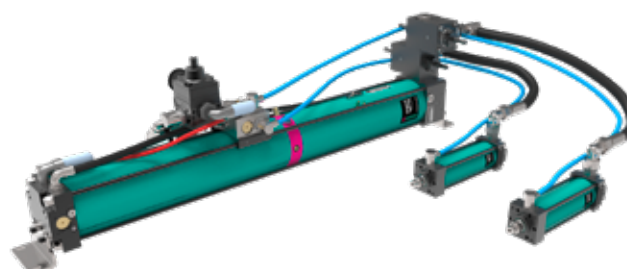

TOX[®]-Working Cylinder X-AT

The pneumatic TOX[®]-Working Cylinder X-AT with double-bearing working piston and absolute air-oil separation provides fast approach stroke and return stroke by applying pressure to the working cylinder. This results in high stroke forces, fast approach and return stroke forces. The power stroke is carried out by the TOX[®]-Pressure Intensifier X-ES.

Up to 6 TOX[®]-Working Cylinders X-AT can be connected to one pressure intensifier (more on request).

Advantages

- High fast approach and return stroke forces
- Short cycle-times
- Fixed stop with elastomer cushioning
- Prepared for stroke monitoring ZHU and external linear position sensor ZHW up to X-AT-030
- Hydraulic cushioning for return stroke
- Bypass ZLB and hydraulic end position cushioning ZHD

See pages 10 – 12

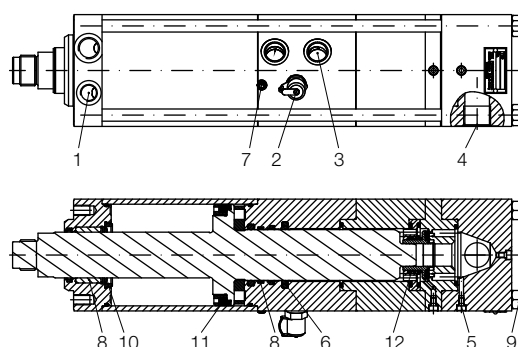

- | | |
|--|--|
| 1 Return stroke connection (closed) | 7 Absolute air-oil separation |
| 2 Oil high pressure measuring connection | 8 Double-bearing working piston |
| 3 Fast approach stroke connection (closed) | 9 Flexible tie rod |
| 4 Oil high pressure port from X-ES | 10 Elastomer cushioning |
| 5 Bleed screw | 11 Magnet ring for stroke monitoring |
| 6 Special seals | 12 Bypass with hydraulic end position cushioning |

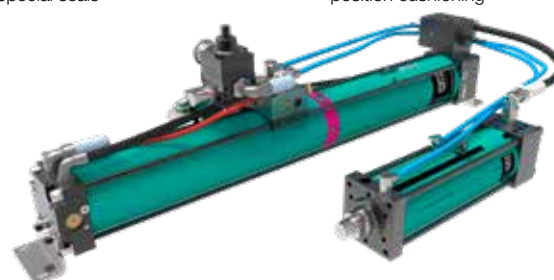

Design of a TOX[®]-X-KT-System

Example calculation of a combination of TOX[®]-Pressure Intensifier X-ES and TOX[®]-Hydraulic Cylinder HZL

To figure out what combination of TOX[®]-Pressure Intensifier X-ES and TOX[®]-Working Cylinders HZL is appropriate for you, we give you the following sample calculation. The values you have to provide are shown in red. That means: you define the required press force, total stroke and power stroke of the cylinder.

Furthermore you have to determine the number of cylinders installed to one intensifier and the hose lengths. Following this sample calculation also combinations of TOX[®]-Hydraulic Cylinders HZL with total stroke adjustment or TOX[®]-Pressure Intensifiers X-ES with TOX[®]-Working Cylinders can be specified.

Example: You need **60** kN press force, **100** mm total stroke, **14** mm power stroke and you want **2** HZL connected to one intensifier X-ES. You need one hydrosplit coupling ZHK for each working cylinder (factor for calculation: ZHK 020 = 1.5) and one hose with **800** mm length. (**■** defined data **■** data from table on page 5 **■** calculated figures)

- a** The required press force e.g. **60** kN leads to the selection of a cylinder with max. **76** kN press force. The calculation results in 197 bar required oil pressure. Attention: max. 250 bar possible!

Calculation for system selection

$$\begin{array}{l} \text{Max. oil pressure bar} \\ 250 \end{array} \div \begin{array}{l} \text{Max. press force kN} \\ 76 \end{array} \times \begin{array}{l} \text{Required press force for application kN} \\ 60 \end{array} = \begin{array}{l} \text{Required oil pressure for application bar} \\ 197 \end{array}$$

- b** The volume required in your case can be determined by multiplying the required power stroke (e.g. **14** mm) by the type specific volume factor V (e.g. **3.1**). The factors $F_1 + F_2$ are added to the previous result (whereby F_2 depends on the hose length e.g. **800** mm). Then add a factor of 1.5 for each ZHK 020 hydrosplit coupling, equals 56.6. Finally, this multiplied by the number of cylinders e.g. **2**, results in **113.2** cm³ oil volume. This leads to the selection of an intensifier X-ES with 123 cm³, the X-ES 125.000.0123.48.

Required total delivery volume for power stroke

Required delivery volume per 1 mm power stroke	Required power stroke for the application	Factor 1 depending on total stroke	Factor 2 per 100mm hose length	Required delivery volume for power stroke	Amount cylinders	Required total delivery volume for power stroke for the application
V 3.1	x 14 mm	+ F_1 6.9	+ F_2 (0.6 x 8)	+ 1.5* = 56.6 cm ³	x 2	= 113.2 cm ³

*ZHK 020 = 1.5 / ZHK 042 = 11

- c** The stroke required for your application leads to the selection of a cylinder with a total stroke of **100** mm and defines the type of cylinder. Multiply the delivery volume factor V by the number of cylinders (e.g. **2**) equals in the total delivery volume of 620 cm³. Check whether this is possible with the selected intensifier. This intensifier delivers e.g. **1300** cm³. Therefore it's enough.

Required total delivery volume for fast approach stroke

Required delivery volume per 1 mm total stroke	Total stroke of cylinder	Required delivery volume for fast approach stroke	Amount cylinders	Required total delivery volume for fast approach stroke for the application
V 3.1	x 100 mm	= 310 cm ³	x 2	= 620 cm ³

- d** The oil pressure calculated **a** e.g. 197 bar is divided by the oil pressure produced by the intensifier at 1 bar air pressure (e.g. **40**). The result is the required air pressure (e.g. **4.9** bar). In order to obtain high stroke frequencies, the air pressure should always be about 20 % higher (e.g. 5.9 bar). Caution: the maximum pressure / press force of the cylinder must not be exceeded.

$$\begin{array}{l} \text{Calculated oil pressure} \\ 197 \text{ bar} \end{array} \div \begin{array}{l} \text{Required air pressure for application} \\ 40 \end{array} = \begin{array}{l} \text{Required air pressure for application} \\ 4.9 \text{ bar} \end{array}$$

Note: When using different cylinders and different hose lengths, the calculation of the volume must be done individually for each cylinder. Then add the combined results.

TOX®-Hydraulic Cylinder HZL max. 250 bar oil pressure

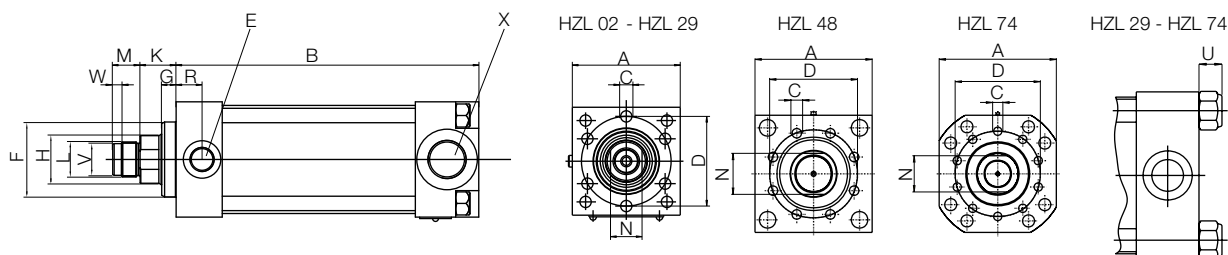

Forces

Type	Max. Press force at 250 bar oil pressure kN	Version	Total stroke	Fast approach force at 6 bar air pressure N	Return force at 6 bar air pressure N	V cm ³	F ₁ mm	F ₂ per 100 mm hose length	Weight kg
HZL 02.101. 50	23	101	50	170	100	0.9	0.9	0.2	2
HZL 02.101.100	23	101	100	170	100	0.9	1.7	0.2	2
HZL 02.101.150	23	101	150	170	100	0.9	2.4	0.2	3
HZL 02.101.200	23	101	200	170	100	0.9	3.2	0.2	3
HZL 05.101. 50	48	101	50	400	250	2.0	2.2	0.5	4
HZL 05.101.100	48	101	100	400	250	2.0	4.3	0.5	5
HZL 05.101.150	48	101	150	400	250	2.0	6.5	0.5	5
HZL 05.101.200	48	101	200	400	250	2.0	8.6	0.5	6
HZL 07.101. 50	76	101	50	700	350	3.1	3.4	0.6	7
HZL 07.101.100	a 76	101	100	700	350	b 3.1	b 6.9	b 0.6	8
HZL 07.101.150	76	101	150	700	350	3.1	10.3	0.6	9
HZL 07.101.200	76	101	200	700	350	3.1	13.7	0.6	10
HZL 11.101. 50	108	101	50	1150	700	4.4	4.9	0.6	10
HZL 11.101.100	108	101	100	1150	700	4.4	9.7	0.6	11
HZL 11.101.150	108	101	150	1150	700	4.4	14.6	0.6	12
HZL 11.101.200	108	101	200	1150	700	4.4	19.4	0.6	14
HZL 19.101. 50	192	101	50	2100	1250	7.9	8.6	0.7	21
HZL 19.101.100	192	101	100	2100	1250	7.9	17.3	0.7	24
HZL 19.101.150	192	101	150	2100	1250	7.9	25.9	0.7	26
HZL 19.101.200	192	101	200	2100	1250	7.9	34.5	0.7	29
HZL 29.101. 50	300	101	50	3550	2350	12.3	13.5	0.7	46
HZL 29.101.100	300	101	100	3550	2350	12.3	27.0	0.7	49
HZL 29.101.150	300	101	150	3550	2350	12.3	40.6	0.7	53
HZL 29.101.200	300	101	200	3550	2350	12.3	54.1	0.7	57
HZL 48.101. 50	492	101	50	6300	3900	20.1	22.0	0.7	78
HZL 48.101.100	492	101	100	6300	3900	20.1	44.0	0.7	84
HZL 48.101.150	492	101	150	6300	3900	20.1	66.0	0.7	91
HZL 48.101.200	492	101	200	6300	3900	20.1	88.0	0.7	97
HZL 74.101. 50	770	101	50	10500	6550	31.4	35.0	0.7	152
HZL 74.101.100	770	101	100	10500	6550	31.4	70.0	0.7	161
HZL 74.101.150	770	101	150	10500	6550	31.4	105.0	0.7	171
HZL 74.101.200	770	101	200	10500	6550	31.4	140.0	0.7	180

Notice: The specified press force includes the fast approach force.

For mounting specifications see data sheet 10.18 TOX®-Powerpackage. Pressure tolerances ± 5 %.

Dimensions in mm

TOX[®]-Hydraulic Cylinder HZL max. 250 bar oil pressure

Dimensions

Type	A	B	C	D	E*	F ₁₇	G	H	K	L	M	N	W	V _{g6}	R	U	X hydr.
HZL 02.101. 50	55	158	6xM6x12	42	G1/8"	32	9.5	16	27	M12x1.5	12	14	4	10	10	-	G1/4"
HZL 02.101.100	55	208	6xM6x12	42	G1/8"	32	9.5	16	27	M12x1.5	12	14	4	10	10	-	G1/4"
HZL 02.101.150	55	258	6xM6x12	42	G1/8"	32	9.5	16	27	M12x1.5	12	14	4	10	10	-	G1/4"
HZL 02.101.200	55	308	6xM6x12	42	G1/8"	32	9.5	16	27	M12x1.5	12	14	4	10	10	-	G1/4"
HZL 05.101. 50	65	190	6xM8x12	54	G3/8"	40	10.0	25	25	M16x1.5	15	19	4	14	14	-	G1/2"
HZL 05.101.100	65	240	6xM8x12	54	G3/8"	40	10.0	25	25	M16x1.5	15	19	4	14	14	-	G1/2"
HZL 05.101.150	65	290	6xM8x12	54	G3/8"	40	10.0	25	25	M16x1.5	15	19	4	14	14	-	G1/2"
HZL 05.101.200	65	340	6xM8x12	54	G3/8"	40	10.0	25	25	M16x1.5	15	19	4	14	14	-	G1/2"
HZL 07.101. 50	80	210	6xM8x16	65	G3/8"	52	10.0	35	25	M24x1.5	19	30	6	22	18	-	G3/4"
HZL 07.101.100	80	260	6xM8x16	65	G3/8"	52	10.0	35	25	M24x1.5	19	30	6	22	18	-	G3/4"
HZL 07.101.150	80	310	6xM8x16	65	G3/8"	52	10.0	35	25	M24x1.5	19	30	6	22	18	-	G3/4"
HZL 07.101.200	80	360	6xM8x16	65	G3/8"	52	10.0	35	25	M24x1.5	19	30	6	22	18	-	G3/4"
HZL 11.101. 50	90	210	6xM10x16	68	G3/8"	52	10.0	35	25	M24x1.5	19	30	6	22	18	-	G3/4"
HZL 11.101.100	90	260	6xM10x16	68	G3/8"	52	10.0	35	25	M24x1.5	19	30	6	22	18	-	G3/4"
HZL 11.101.150	90	310	6xM10x16	68	G3/8"	52	10.0	35	25	M24x1.5	19	30	6	22	18	-	G3/4"
HZL 11.101.200	90	360	6xM10x16	68	G3/8"	52	10.0	35	25	M24x1.5	19	30	6	22	18	-	G3/4"
HZL 19.101. 50	125	235	6xM16x25	100	G1/2"	75	10.0	50	28	M30x2	25	41	7	26	24	-	G1"
HZL 19.101.100	125	285	6xM16x25	100	G1/2"	75	10.0	50	28	M30x2	25	41	7	26	24	-	G1"
HZL 19.101.150	125	335	6xM16x25	100	G1/2"	75	10.0	50	28	M30x2	25	41	7	26	24	-	G1"
HZL 19.101.200	125	385	6xM16x25	100	G1/2"	75	10.0	50	28	M30x2	25	41	7	26	24	-	G1"
HZL 29.101. 50	160	298	6xM20x30	115	G3/4"	80	15.0	55	47	M39x2	35	50	-	-	27	22	G1"
HZL 29.101.100	160	348	6xM20x30	115	G3/4"	80	15.0	55	47	M39x2	35	50	-	-	27	22	G1"
HZL 29.101.150	160	398	6xM20x30	115	G3/4"	80	15.0	55	47	M39x2	35	50	-	-	27	22	G1"
HZL 29.101.200	160	448	6xM20x30	115	G3/4"	80	15.0	55	47	M39x2	35	50	-	-	27	22	G1"
HZL 48.101. 50	200	300	8xM20x30	150	G3/4"	125	25.0	80	60	M64x2	60	70	-	-	27	30	G1"
HZL 48.101.100	200	350	8xM20x30	150	G3/4"	125	25.0	80	60	M64x2	60	70	-	-	27	30	G1"
HZL 48.101.150	200	400	8xM20x30	150	G3/4"	125	25.0	80	60	M64x2	60	70	-	-	27	30	G1"
HZL 48.101.200	200	450	8xM20x30	150	G3/4"	125	25.0	80	60	M64x2	60	70	-	-	27	30	G1"
HZL 74.101. 50	275	366	10xM24x40	200	G3/4"	150	25.0	100	65	M64x2	60	85	-	-	38	30	G1"
HZL 74.101.100	275	416	10xM24x40	200	G3/4"	150	25.0	100	65	M64x2	60	85	-	-	38	30	G1"
HZL 74.101.150	275	466	10xM24x40	200	G3/4"	150	25.0	100	65	M64x2	60	85	-	-	38	30	G1"
HZL 74.101.200	275	516	10xM24x40	200	G3/4"	150	25.0	100	65	M64x2	60	85	-	-	38	30	G1"

*Pneumatic supply at the intensifier X-ES, connection sizes see X-ES, pneumatic connection 2 and 4.

Dimensions in mm

Pneumatic connection sizes

Connection	Nominal sizes/Inside-Ø hose
G1/4"	7 - 8 mm
G3/8"	8 - 9 mm
G1/2"	10 - 11 mm
G3/4"	19 - 20 mm
G1"	25 mm
G1 1/2"	38 mm

Note: For a trouble-free operation, the connection size and nominal size must be maintained throughout the compressed air supply.

TOX®-Pressure Intensifier X-ES

in combination with the TOX®-Hydraulic Cylinder HZL

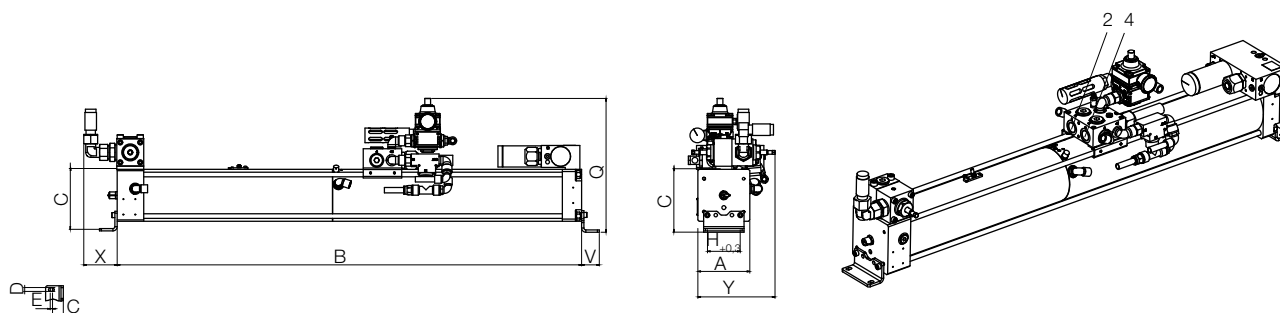

Forces

Type	Pneumatic connection [4]		Hydraulic connection high pressure	Delivery volume for fast approach stroke cm ³	Delivery volume for power stroke cm ³	Oil		Maximum number of hydrosplit coupling direct	Amount of hydrosplit couplings with adapter 603	Weight kg****
	Fast approach/ power stroke	[2] Return stroke				pressure at 1 bar air pressure bar	Oil pressure at 6 bar air pressure bar			
X-ES 100.000.0060.51	G1/2"	G1/2"	G1/2"	600	60	42**	255***	3xZHK020	4 – 6	43
X-ES 125.000.0123.48	G3/4"	G3/4"	G3/4"	c 1300	b 123	d 40**	241***	3xZHK020	4 – 6	70
X-ES 180.000.0322.52	G1"	G1"	G1"	4300	322	43**	259***	–	1 – 6	158
X-ES 250.000.0692.51	G1"	G1"	SAE 2"	10000	692	42**	255***	1xZHK042	1 – 6	317
X-ES 300.000.1300.51	G1"	G1"	SAE 2"	20000	1300	42**	255***	1xZHK042	1 – 6	559

Note: Unless specified otherwise the max. permissible oil pressure is 400 bar for all intensifiers of the type X-ES. It must not be exceeded.

** Attention: Pressure and force values to be considered as calculation basis for preselection. The real values can differ.

*** Pressure tolerance ± 5%

**** Weight data for X-ES including pneumatic control and hydrosplit coupling ZHK 020.

Dimensions

Type	A	B	C	D	E	G	H	Q	V	ZHK 020		ZHK 042		Y
										X _{max}	X _{max}	X _{max}	X _{max}	
X-ES 100.000.0060.51	110	999	135	9	6	28	85	305	46	100	–	–	–	233
X-ES 125.000.0123.48	135	1207	160	9	6	28	85	345	46	100	–	–	–	246
X-ES 180.000.0322.52	190	1569	230	14	20	45	100	427	88	100	–	–	–	273
X-ES 250.000.0692.51	267	1731	307	14	20	45	100	505	88	100	205	–	–	312
X-ES 300.000.1300.51	324	2207	364	14	20	45	100	563	88	100	205	–	–	340

Dimensions in mm

Pneumatic connection sizes

Connection	Nominal sizes /Inside-Ø hose
G1/4"	7 - 8 mm
G3/8"	8 - 9 mm
G1/2"	10 - 11 mm
G3/4"	19 - 20 mm
G1"	25 mm
G1 1/2"	38 mm

Note: For a trouble-free operation, the connection size and nominal size must be maintained throughout the compressed air supply.

TOX[®]-Hydraulic Cylinder HZL xx.151.xx

with total stroke adjustment max. 250 bar oil pressure

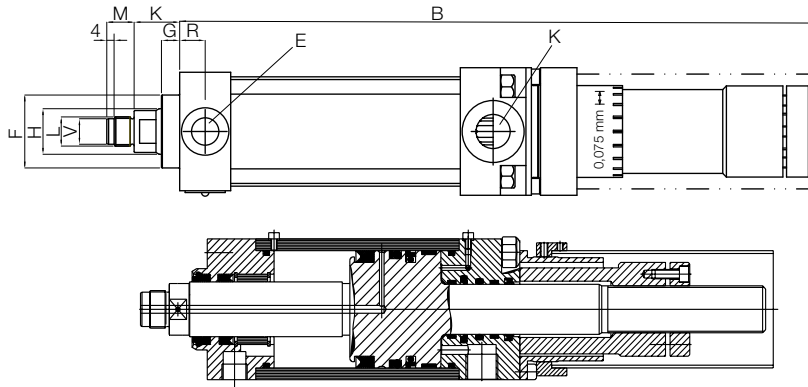

HZL 02 - HZL 29

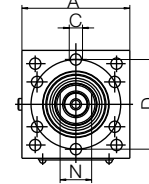

HZL 48

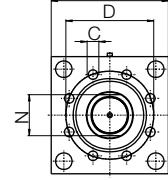

HZL 74

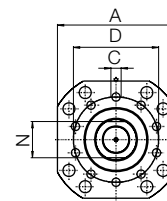

HZL 29 - HZL 74

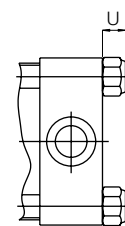

Corresponding TOX[®]-Pressure Intensifier X-ES see page 7.

Forces

Type	Max. Press force at d 250 bar oil pressure kN	Version	Total stroke	Fast approach force at 6 bar air pressure N	Return force at 6 bar air pressure N	V cm ³	F ₁ mm	F ₂ per 100 mm hose length	Weight kg
HZL 02.151. 50	18	151	50	70	120	0.8	0.9	0.2	4
HZL 02.151.100	18	151	100	70	120	0.8	1.6	0.2	4
HZL 02.151.150	18	151	150	70	120	0.8	2.3	0.2	5
HZL 02.151.200	18	151	200	70	120	0.8	3.1	0.2	6
HZL 05.151. 50	38	151	50	260	290	1.6	2.0	0.5	6
HZL 05.151.100	38	151	100	260	290	1.6	4.0	0.5	8
HZL 05.151.150	38	151	150	260	290	1.6	5.5	0.5	9
HZL 05.151.200	38	151	200	260	290	1.6	7.0	0.5	11
HZL 07.151. 50	61	151	50	480	410	2.5	3.2	0.5	10
HZL 07.151.100	a 61	151	100	480	410	b 2.5	b 6.5	b 0.5	12
HZL 07.151.150	61	151	150	480	410	2.5	8.9	0.5	14
HZL 07.151.200	61	151	200	480	410	2.5	11.3	0.5	16
HZL 11.151. 50	88	151	50	850	850	3.6	4.5	0.5	13
HZL 11.151.100	88	151	100	850	850	3.6	9.2	0.5	16
HZL 11.151.150	88	151	150	850	850	3.6	12.6	0.5	18
HZL 11.151.200	88	151	200	850	850	3.6	16.0	0.5	21
HZL 19.151. 50	153	151	50	1480	1420	6.3	8.0	0.7	28
HZL 19.151.100	153	151	100	1480	1420	6.3	16.3	0.7	32
HZL 19.151.150	153	151	150	1480	1420	6.3	22.3	0.7	38
HZL 19.151.200	153	151	200	1480	1420	6.3	28.4	0.7	43
HZL 29.151. 50	252	151	50	2770	2540	10.3	12.7	0.7	56
HZL 29.151.100	252	151	100	2770	2540	10.3	25.8	0.7	63
HZL 29.151.150	252	151	150	2770	2540	10.3	35.2	0.7	71
HZL 29.151.200	252	151	200	2770	2540	10.3	44.7	0.7	79
HZL 48.151. 50	411	151	50	5000	4230	16.8	20.7	0.7	92
HZL 48.151.100	411	151	100	5000	4230	16.8	42.2	0.7	104
HZL 48.151.150	411	151	150	5000	4230	16.8	57.7	0.7	116
HZL 48.151.200	411	151	200	5000	4230	16.8	73.2	0.7	128
HZL 74.151. 50	577	151	50	7470	7330	23.6	31.5	0.7	186
HZL 74.151.100	577	151	100	7470	7330	23.6	64.1	0.7	207
HZL 74.151.150	577	151	150	7470	7330	23.6	88.4	0.7	228
HZL 74.151.200	577	151	200	7470	7330	23.6	112.6	0.7	249

Notice: The specified press force includes the fast approach force.

For mounting specifications see data sheet 10.18 TOX[®]-Powerpackage. Pressure tolerances ± 5 %.

Dimensions in mm

TOX®-Hydraulic Cylinder HZL xx.151.xx

Dimensions

Type	A	B	C	D	E*	F _{fr}	G	H	K	L	M	N	W	V _{g6}	R	U	X hydr.
HZL 02.151.50	55	328	6xM6x12	42	G1/8"	32	9.5	16	27	M12x1.5	12	14	4	10	10	-	G1/4"
HZL 02.151.100	55	478	6xM6x12	42	G1/8"	32	9.5	16	27	M12x1.5	12	14	4	10	10	-	G1/4"
HZL 02.151.150	55	628	6xM6x12	42	G1/8"	32	9.5	16	27	M12x1.5	12	14	4	10	10	-	G1/4"
HZL 02.151.200	55	778	6xM6x12	42	G1/8"	32	9.5	16	27	M12x1.5	12	14	4	10	10	-	G1/4"
HZL 05.151.50	65	349	6xM8x12	54	G3/8"	40	10.0	25	25	M16x1.5	15	19	4	14	14	-	G1/2"
HZL 05.151.100	65	506.5	6xM8x12	54	G3/8"	40	10.0	25	25	M16x1.5	15	19	4	14	14	-	G1/2"
HZL 05.151.150	65	656.5	6xM8x12	54	G3/8"	40	10.0	25	25	M16x1.5	15	19	4	14	14	-	G1/2"
HZL 05.151.200	65	806.5	6xM8x12	54	G3/8"	40	10.0	25	25	M16x1.5	15	19	4	14	14	-	G1/2"
HZL 07.151.50	80	373.5	6xM8x16	65	G3/8"	52	10.0	35	25	M24x1.5	19	30	6	22	18	-	G1/2"
HZL 07.151.100	80	517	6xM8x16	65	G3/8"	52	10.0	35	25	M24x1.5	19	30	6	22	18	-	G1/2"
HZL 07.151.150	80	667	6xM8x16	65	G3/8"	52	10.0	35	25	M24x1.5	19	30	6	22	18	-	G1/2"
HZL 07.151.200	80	817	6xM8x16	65	G3/8"	52	10.0	35	25	M24x1.5	19	30	6	22	18	-	G1/2"
HZL 11.151.50	90	373	6xM10x16	68	G3/8"	52	10.0	35	25	M24x1.5	19	30	6	22	18	-	G1/2"
HZL 11.151.100	90	523	6xM10x16	68	G3/8"	52	10.0	35	25	M24x1.5	19	30	6	22	18	-	G1/2"
HZL 11.151.150	90	675	6xM10x16	68	G3/8"	52	10.0	35	25	M24x1.5	19	30	6	22	18	-	G1/2"
HZL 11.151.200	90	823	6xM10x16	68	G3/8"	52	10.0	35	25	M24x1.5	19	30	6	22	18	-	G1/2"
HZL 19.151.50	125	418	6xM16x25	100	G1/2"	75	10.0	50	28	M30x2	25	41	7	26	24	-	G1"
HZL 19.151.100	125	568	6xM16x25	100	G1/2"	75	10.0	50	28	M30x2	25	41	7	26	24	-	G1"
HZL 19.151.150	125	718	6xM16x25	100	G1/2"	75	10.0	50	28	M30x2	25	41	7	26	24	-	G1"
HZL 19.151.200	125	868	6xM16x25	100	G1/2"	75	10.0	50	28	M30x2	25	41	7	26	24	-	G1"
HZL 29.151.50	160	498	6xM20x30	115	G3/4"	80	15.0	55	47	M39x2	35	50	-	-	27	22	G1"
HZL 29.151.100	160	648	6xM20x30	115	G3/4"	80	15.0	55	47	M39x2	35	50	-	-	27	22	G1"
HZL 29.151.150	160	798	6xM20x30	115	G3/4"	80	15.0	55	47	M39x2	35	50	-	-	27	22	G1"
HZL 29.151.200	160	948	6xM20x30	115	G3/4"	80	15.0	55	47	M39x2	35	50	-	-	27	22	G1"
HZL 48.151.50	200	505	8xM20x30	150	G3/4"	125	25.0	80	60	M64x2	60	70	-	-	27	30	G1"
HZL 48.151.100	200	655	8xM20x30	150	G3/4"	125	25.0	80	60	M64x2	60	70	-	-	27	30	G1"
HZL 48.151.150	200	805	8xM20x30	150	G3/4"	125	25.0	80	60	M64x2	60	70	-	-	27	30	G1"
HZL 48.151.200	200	955	8xM20x30	150	G3/4"	125	25.0	80	60	M64x2	60	70	-	-	27	30	G1"
HZL 74.151.50	275	612	10xM24x40	200	G3/4"	150	25.0	100	65	M64x2	60	85	-	-	38	30	G1"
HZL 74.151.100	275	762	10xM24x40	200	G3/4"	150	25.0	100	65	M64x2	60	85	-	-	38	30	G1"
HZL 74.151.150	275	912	10xM24x40	200	G3/4"	150	25.0	100	65	M64x2	60	85	-	-	38	30	G1"
HZL 74.151.200	275	1062	10xM24x40	200	G3/4"	150	25.0	100	65	M64x2	60	85	-	-	38	30	G1"

*Pneumatic supply at the intensifier X-ES, connection sizes see X-ES, pneumatic connection 2 and 4.

Dimensions in mm

Pneumatic connection sizes

Connection	Nominal sizes/Inside-Ø hose
G1/4"	7 - 8 mm
G3/8"	8 - 9 mm
G1/2"	10 - 11 mm
G3/4"	19 - 20 mm
G1"	25 mm
G1 1/2"	38 mm

Note: For a trouble-free operation, the connection size and nominal size must be maintained throughout the compressed air supply.

Adapter for working piston (with internal thread to fit the piston rod end)

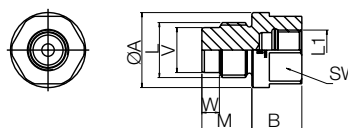

Type	Fits to	ØA	B	L1	L	M	W	V _{g6}	SW
HZZ 012.016.020.000	HZL 02	22	20	M12x1.5	M16x1.5	15	4	14	19
HZZ 016.022.020.000	HZL 05	30	20	M16x1.5	M22x2	20	7	18	27
HZZ 024.030.030.000	HZL 07 / HZL 11	45	30	M24x1.5	M30x2	25	7	26	41
HZZ 030.039.040.000	HZL 19	56	40	M30x2	M39x2	35	-	-	50

Dimensions in mm

TOX[®]-Working Cylinder X-AT max. 400 bar oil pressure

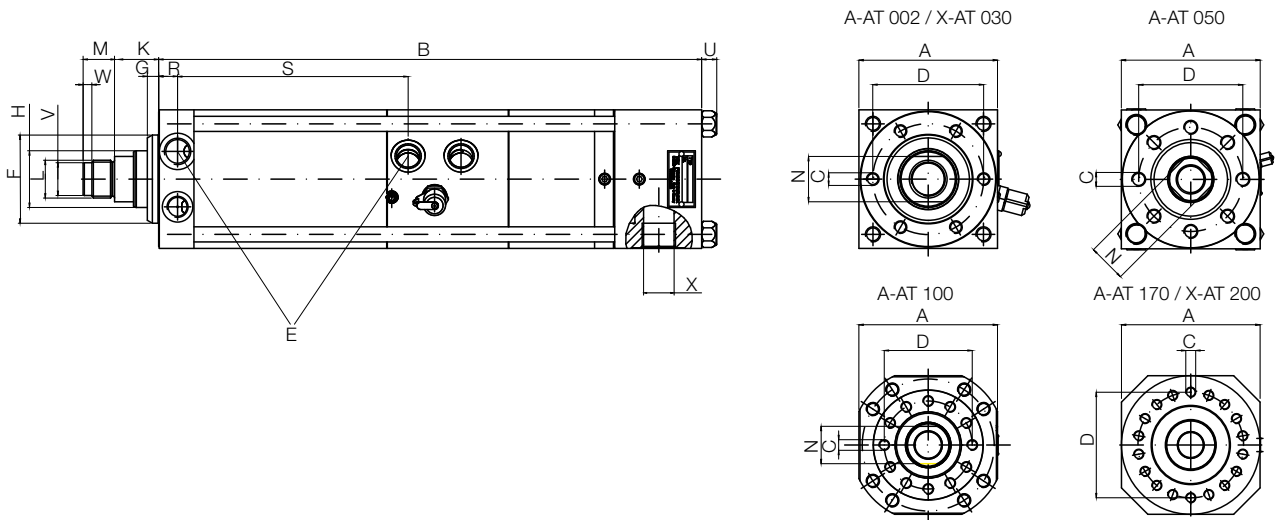

Forces

Type	Max. Press force at 400 bar oil pressure kN	Version	Total stroke	Fast approach force at 6 bar air pressure N	Return force at 6 bar air pressure N	V cm ³	F ₁ mm	F ₂ per 100 mm hose length	Weight kg
X-AT 002.000.100	21	000	100	1700	1460	0.49	1.4	0.7	9
X-AT 002.000.200	21	000	200	1700	1460	0.49	2.6	0.7	13
X-AT 002.000.300	21	000	300	1700	1460	0.49	3.9	0.7	17
X-AT 004.000.100	52	000	100	2430	1870	1.26	3.9	0.7	15
X-AT 004.000.200	52	000	200	2430	1870	1.26	7.0	0.7	21
X-AT 004.000.400	52	000	400	2430	1870	1.26	13.2	0.7	32
X-AT 008.000.100	a 81	000	100	4320	3180	b 1.96	b 6.5	b 0.9	28
X-AT 008.000.200	81	000	200	4320	3180	1.96	11.2	0.9	37
X-AT 008.000.400	81	000	400	4320	3180	1.96	20.6	0.9	57
X-AT 015.000.100	158	000	100	6780	5180	3.85	12.9	1.1	43
X-AT 015.000.200	158	000	200	6780	5180	3.85	21.9	1.1	58
X-AT 015.000.400	158	000	400	6780	5180	3.85	40.0	1.1	87
X-AT 030.000.100	320	000	100	11170	8740	7.85	26.5	1.7	77
X-AT 030.000.200	320	000	200	11170	8740	7.85	44.7	1.7	100
X-AT 030.000.400	320	000	400	11170	8740	7.85	81.0	1.7	145
X-AT 050.000.100	498	000	100	14230	10830	12.27	34.8	1.7	113
X-AT 050.000.200	498	000	200	14230	10830	12.27	62.8	1.7	144
X-AT 050.000.400	498	000	400	14230	10830	12.27	119.1	1.7	206
X-AT 100.000.100	1030	000	100	27520	19720	25.45	71.4	3.1	262
X-AT 100.000.200	1030	000	200	27520	19720	25.45	129.2	3.1	326
X-AT 100.000.300	1030	000	300	27520	19720	25.45	187.0	3.1	390
X-AT 170.000.100	1670	000	100	15700	25300	41.55	116.1	3.1	556
X-AT 170.000.200	1670	000	200	15700	25300	41.55	210.0	3.1	643
X-AT 170.000.400	1670	000	400	15700	25300	41.55	397.9	3.1	817
X-AT 200 on request									

Notice: The specified press force includes the fast approach force. For mounting specifications see data sheet 10.18 TOX[®]-Powerpackage, pressure tolerances ± 5 %.

Dimensions in mm

TOX®-Working Cylinder X-AT max. 400 bar oil pressure

Dimensions

Type	A	B	C	D	E_{RH}^* E_{EH}^* E_{RH}^*	F_{T7}	G	H	K	L	M	N	R	S	V_{g6}	W	U	X hydr.
X-AT 002.000.100	70	377	6xM8x12	54	G1/4"	40	9	20	26.0	M16x1.5	15	17	13	166.0	-	-	8	G1/2"
X-AT 002.000.200	70	577	6xM8x12	54	G1/4"	40	9	20	26.0	M16x1.5	15	17	13	266.0	-	-	8	G1/2"
X-AT 002.000.300	70	777	6xM8x12	54	G1/4"	40	9	20	26.0	M16x1.5	15	17	13	366.0	-	-	8	G1/2"
X-AT 004.000.100	85	402	6xM8x15	64	G3/8"	50	10	30	28.5	M22x2	20	24	14	175.0	18	7	10	G1/2"
X-AT 004.000.200	85	602	6xM8x15	64	G3/8"	50	10	30	28.5	M22x2	20	24	14	275.0	18	7	10	G1/2"
X-AT 004.000.400	85	1002	6xM8x15	64	G3/8"	50	10	30	28.5	M22x2	20	24	14	475.0	18	7	10	G1/2"
X-AT 008.000.100	110	431	6xM10x16	88	G1/2"	70	9	45	35.0	M30x2	25	36	15	183.0	26	7	12	G3/4"
X-AT 008.000.200	110	631	6xM10x16	88	G1/2"	70	9	45	35.0	M30x2	25	36	15	283.0	26	7	12	G3/4"
X-AT 008.000.400	110	1031	6xM10x16	88	G1/2"	70	9	45	35.0	M30x2	25	36	15	483.0	26	7	12	G3/4"
X-AT 015.000.100	135	450	6xM16x25	100	G1/2"	75	15	50	36.0	M30x2	25	41	17.5	184.5	26	7	16	G1"
X-AT 015.000.200	135	650	6xM16x25	100	G1/2"	75	15	50	36.0	M30x2	25	41	17.5	284.5	26	7	16	G1"
X-AT 015.000.400	135	1050	6xM16x25	100	G1/2"	75	15	50	36.0	M30x2	25	41	17.5	484.5	26	7	16	G1"
X-AT 030.000.100	170	500	6xM20x30	132	G3/4"	100	17	56	47.0	M39x2	35	50	20	236.0	-	-	22	G1 1/4"
X-AT 030.000.200	170	700	6xM20x30	132	G3/4"	100	17	56	47.0	M39x2	35	50	20	336.0	-	-	22	G1 1/4"
X-AT 030.000.400	170	1100	6xM20x30	132	G3/4"	100	17	56	47.0	M39x2	35	50	20	536.0	-	-	22	G1 1/4"
X-AT 050.000.100	200	519	8xM20x30	150	G3/4"	115	25	63	52.0	M42x2	40	55	23	243.0	-	-	30	G1 1/4"
X-AT 050.000.200	200	719	8xM20x30	150	G3/4"	115	25	63	52.0	M42x2	40	55	23	343.0	-	-	30	G1 1/4"
X-AT 050.000.400	200	1119	8xM20x30	150	G3/4"	115	25	63	52.0	M42x2	40	55	23	543.0	-	-	30	G1 1/4"
X-AT 100.000.100	310	559	12xM24x40	200	G1"	150	25	100	60.0	M64x2	60	85	40	248.0	-	-	30	SAE 2"
X-AT 100.000.200	310	759	12xM24x40	200	G1"	150	25	100	60.0	M64x2	60	85	40	348.0	-	-	30	SAE 2"
X-AT 100.000.300	310	959	12xM24x40	200	G1"	150	25	100	60.0	M64x2	60	85	40	448.0	-	-	30	SAE 2"
X-AT 170.000.100	420	644	18xM30x55	320	G1"	240	35	150	70.0	M80x2	80	4xØ16	99	253.0	-	-	30	SAE 2"
X-AT 170.000.200	420	844	18xM30x55	320	G1"	240	35	150	70.0	M80x2	80	4xØ16	99	253.0	-	-	30	SAE 2"
X-AT 170.000.400	420	1244	18xM30x55	320	G1"	240	35	150	70.0	M80x2	80	4xØ16	99	253.0	-	-	30	SAE 2"
X-AT 200	on request																	

*Pneumatic supply at the intensifier X-ES, connection sizes see X-ES, pneumatic connection 2 and 4.

Dimensions in mm

Due to the flange connection SAE 2", the X-AT 100 and X-AT 170 types can only be used with intensifiers of the sizes X-ES 250 and X-ES 300.

Pneumatic connection sizes

Connection	Nominal sizes /Inside-Ø hose
G1/4"	7 - 8 mm
G3/8"	8 - 9 mm
G1/2"	10 - 11 mm
G3/4"	19 - 20 mm
G1"	25 mm
G1 1/2"	38 mm

Note: For a trouble-free operation, the connection size and nominal size must be maintained throughout the compressed air supply.

TOX[®]-Pressure Intensifier X-ES

in combination with the TOX[®]-Working Cylinder AT

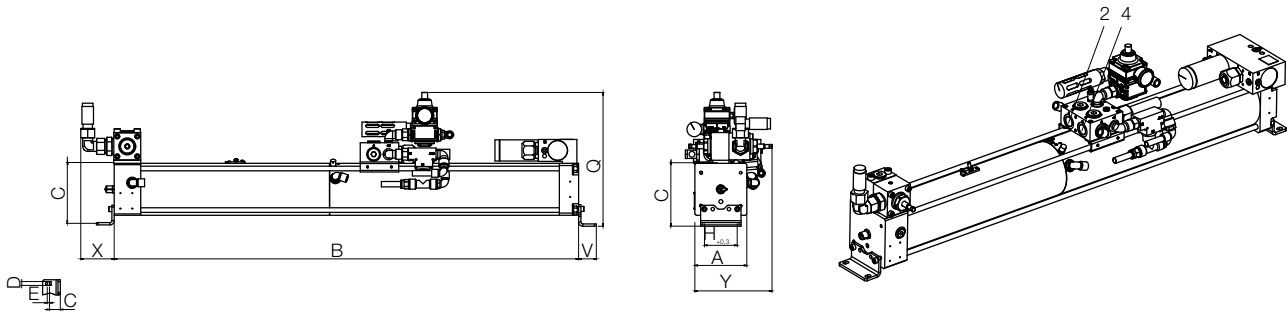

Forces

Type	Pneumatic connection [4]		Hydraulic connection high pressure	Delivery volume for fast approach stroke cm ³	Delivery volume for power stroke cm ³	Oil pressure at 1 bar air pressure bar	Oil pressure at 6 bar air pressure bar	Maximum number of hydrosplit coupling direct	Amount of hydrosplit couplings with adapter 603	Weight kg****
	Fast approach/power stroke	[2] Return stroke								
X-ES 100.000.0043.69	G1/2"	G1/2"	G1/2"	600	43	57**	347***	3xZHK020	4 - 6	43
X-ES 125.000.0070.80	G3/4"	G3/4"	G3/4"	1300	70	66**	398***	3xZHK020	4 - 6	70
X-ES 180.000.0199.81	G1"	G1"	G1"	c 4300	b 199	d 67**	405***	–	1 - 6	158
X-ES 250.000.0424.80	G1"	G1"	SAE 2"	10000	424	66**	398***	1xZHK042	1 - 6	317
X-ES 300.000.0878.73	G1"	G1"	SAE 2"	20000	878	61**	367***	1xZHK042	1 - 6	559

Note: Unless specified otherwise the max. permissible oil pressure is 400 bar for all intensifiers of the type X-ES. It must not be exceeded.

** Attention: Pressure and force values to be considered as calculation basis for preselection. The real values can differ.

*** Pressure tolerance $\pm 5\%$

**** Weight data for X-ES including pneumatic control and hydrosplit coupling ZHK 020.

Dimensions

Type	A	B	C	D	E	G	H	Q	V	ZHK 020	ZHK 042	Y
										X _{max}	X _{max}	
X-ES 100.000.0043.69	110	999	143	9	6	28	85	305	46	100	–	188
X-ES 125.000.0070.80	135	1207	168	9	6	28	85	345	46	100	–	201
X-ES 180.000.0199.81	190	1569	230	14	20	45	100	427	88	100	–	228
X-ES 250.000.0424.80	267	1731	307	14	20	45	100	505	88	100	205	267
X-ES 300.000.0878.73	324	2207	364	14	20	45	100	563	88	100	205	295

Dimensions in mm

Pneumatic connection sizes

Connection	Nominal sizes/Inside-Ø hose
G1/4"	7 - 8 mm
G3/8"	8 - 9 mm
G1/2"	10 - 11 mm
G3/4"	19 - 20 mm
G1"	25 mm
G1 1/2"	38 mm

Note: For a trouble-free operation, the connection size and nominal size must be maintained throughout the compressed air supply.

TOX®-Hydrosplit Coupling type ZHK

Easy separation of pressure intensifier and drive cylinder

In order to ship the components already filled with oil and for easy installation, the TOX®-Hydrosplit Coupling has been

developed. This allows to connect all components without any introduction of air to the system and without leakage. The coupling is available as manual or electric switchable.

TOX®-Hydrosplit Coupling type ZHK 020.000 manually switchable

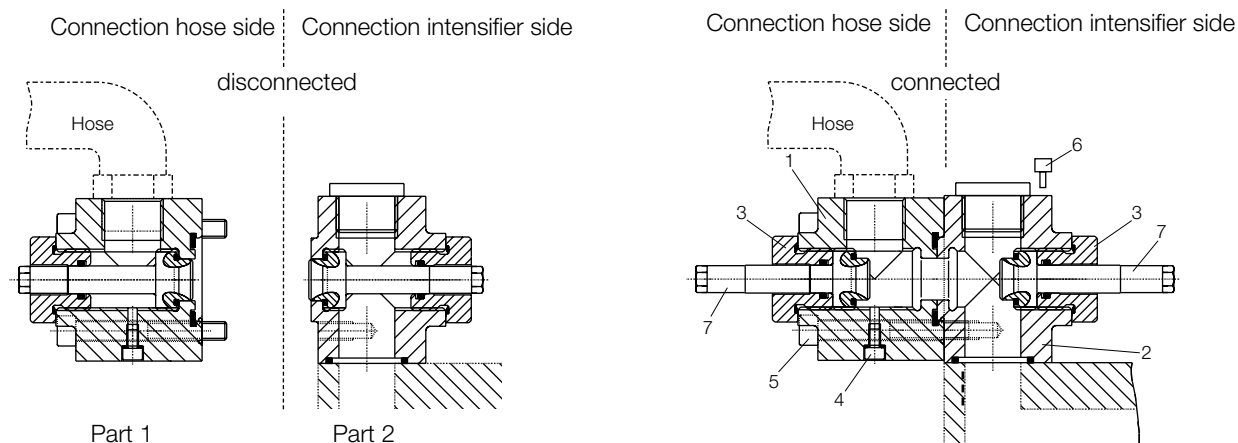

Can be used with drives up to HZL 74 / X-AT 050.
For bigger cylinders request the ZHK 042 (with SAE 2" connection.)

- 1 Coupling half – hose side
- 2 Coupling half – intensifier side
- 3 Threaded bushing – do not open
- 4 Bleed screw
- 5 Coupling assembly screws
- 6 Coupling mounting screws to intensifier
- 7 Valve stem to open or close valve

TOX®-Hydrosplit Coupling type ZHK 020.001 electrically switchable

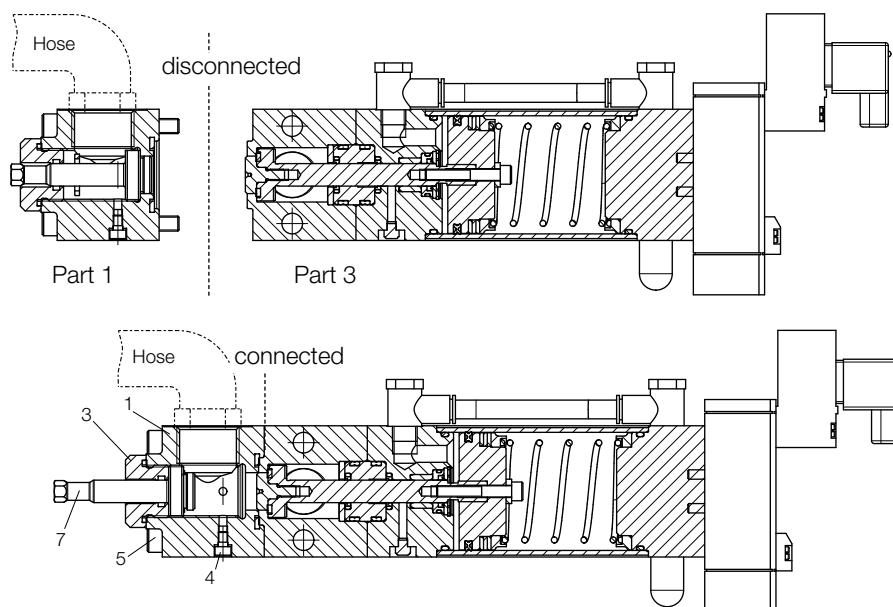

Can be used with drives up to HZL 74 / X-AT 050.

Features:

- Valve is operated with a drive cylinder. No pressure drop
- Cylinders can be activated independently. Return stroke position can be controlled
- One valve size can be used on all cylinders
- Improved cycle time
- Prepared for position feedback

Technical data:

Operating voltage	24 V / DC
Power consumption	4.4 W

Includes solenoid DIN 43650 (ISO 4400) design A, with LED

TOX[®]-Hydrosplit Coupling type ZHK

Combinable with up to 6 drive cylinders

Pressure Intensifier X-ES with up to 3 working cylinders

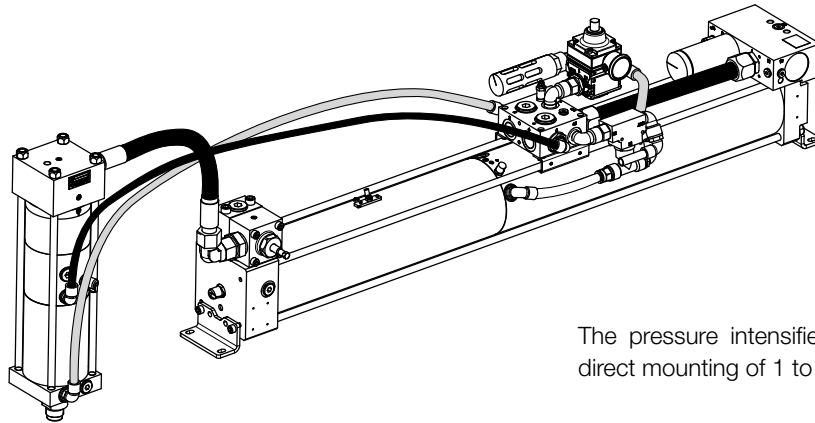

The pressure intensifiers X-ES 100 and X-ES 125 allow direct mounting of 1 to 3 hydrosplit couplings ZHK 020.

Pressure Intensifier X-ES with 4 and more working cylinders

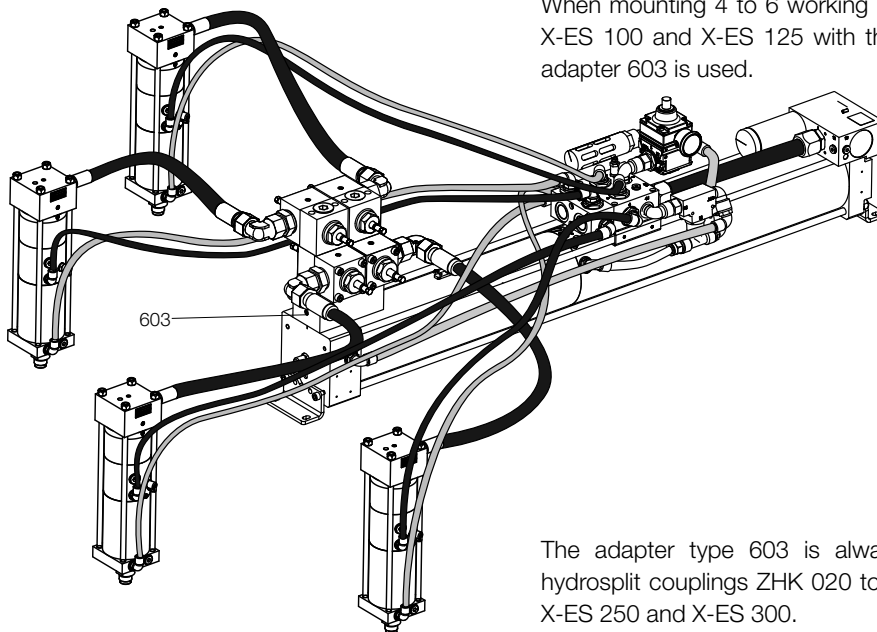

When mounting 4 to 6 working cylinders to the intensifiers X-ES 100 and X-ES 125 with the hydrosplit coupling, the adapter 603 is used.

The adapter type 603 is always used when mounting hydrosplit couplings ZHK 020 to the intensifiers X-ES 180, X-ES 250 and X-ES 300.

Mounting variants of TOX[®]-Hydrosplit Coupling with 1 – 6 hoses

Swivel fitting allows each hose to be independently oriented.

Standard mounting sequence of the TOX[®]-Hydrosplit Coupling ZHK 020

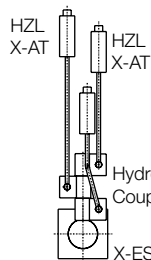
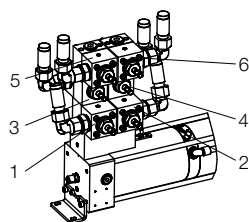

Variant 1

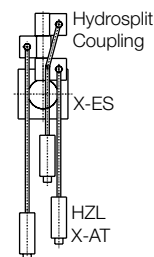

Variant 2

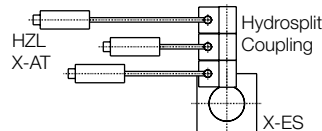

Variant 3

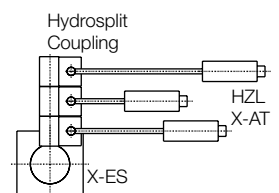

Variant 4

Hydraulic hoses

The connection between the drive cylinders and pneumohydraulic intensifier

Connection variants

Variant no.	Cylinder HZL / X-AT side	Intensifier X-ES side	Connection
ZS 01			2 x straight connection
ZS 02			1 x 90° elbow on X-ES 1 x straight connection on HZL/X-AT
ZS 03			1 x straight connection on X-ES 1 x 90° elbow on HZL/X-AT

Ordering example:

ZS 01 – 1000
 ——— Hose length
 ——— Variant no.



The burst protection hose is part of the standard equipment of the X-KT systems and complies with the applicable Press C-Norm EN 16092-1.

Other connection variants on request.

Allocation of the hydraulic hoses to the drive cylinders

Drive	Standard hose lengths	Nominal size	Hoses \varnothing D	Hose dimensions					Hose weight incl. oil* [kg/m]
				A	B	C	H _{min}	R _{min}	
AT 001	500/1000/1500/2000/2500/3000	10	21	88	75	84	220	150	0.6
X-AT 002/X-AT 004	500/1000/1500/2000/2500/3000	12	24	94	85	92	275	200	0.8
X-AT 008	500/1000/1500/2000/2500/3000	16	28.5	101	90	74	320	240	1.3
X-AT 015	500/1000/1500/2000/2500/3000	19	32	118	125	137	375	280	1.8
X-AT 030/X-AT 050	500/1000/1500/2000/2500/3000	25	39	145	160	100	420	270	2.6
X-AT 100/X-AT 170	1000/1500/2000/2500/3000	50	71	200	200	176	1120	920	6.8
HZL 02	500/1000/1500/2000/2500/3000	10	21	88	75	84	220	150	0.6
HZL 05	500/1000/1500/2000/2500/3000	12	24	94	85	92	275	200	0.8
HZL 07/HZL 11	500/1000/1500/2000/2500/3000	16	28.5	101	90	74	320	240	1.3
HZL 19/HZL 29	500/1000/1500/2000/2500/3000	19	32	118	125	137	375	280	1.8
HZL 48/HZL 74	500/1000/1500/2000/2500/3000	25	39	145	160	100	420	270	2.6

R_{min}: smallest allowable bending radius

*without screw-type fittings

Dimensions in mm

Examples of the correct installation of hydraulic hoses

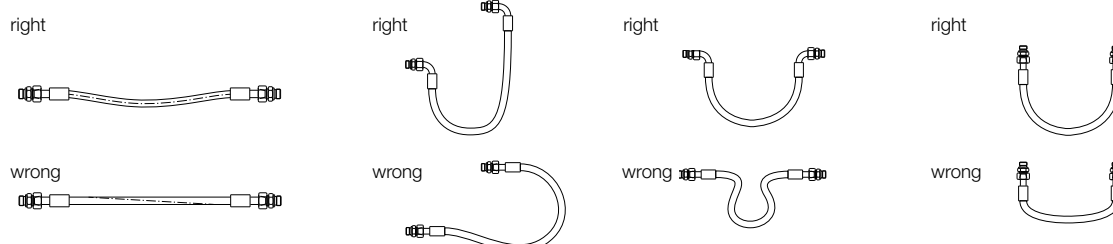

Hoses must be installed so that it can be bled properly!

Pneumatic control diagram

Example

TOX®-Powerpackage X-KT-System for up to 6 drive cylinders (X-AT or HZL) with pneumatic control, power stroke valve and hydrosplit coupling ZHK 020.

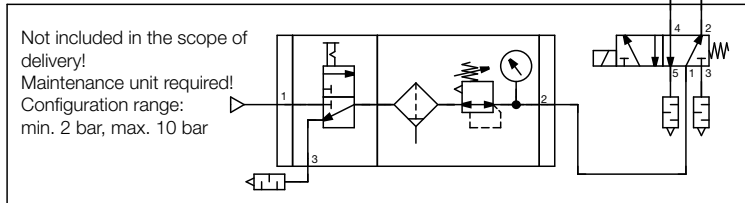
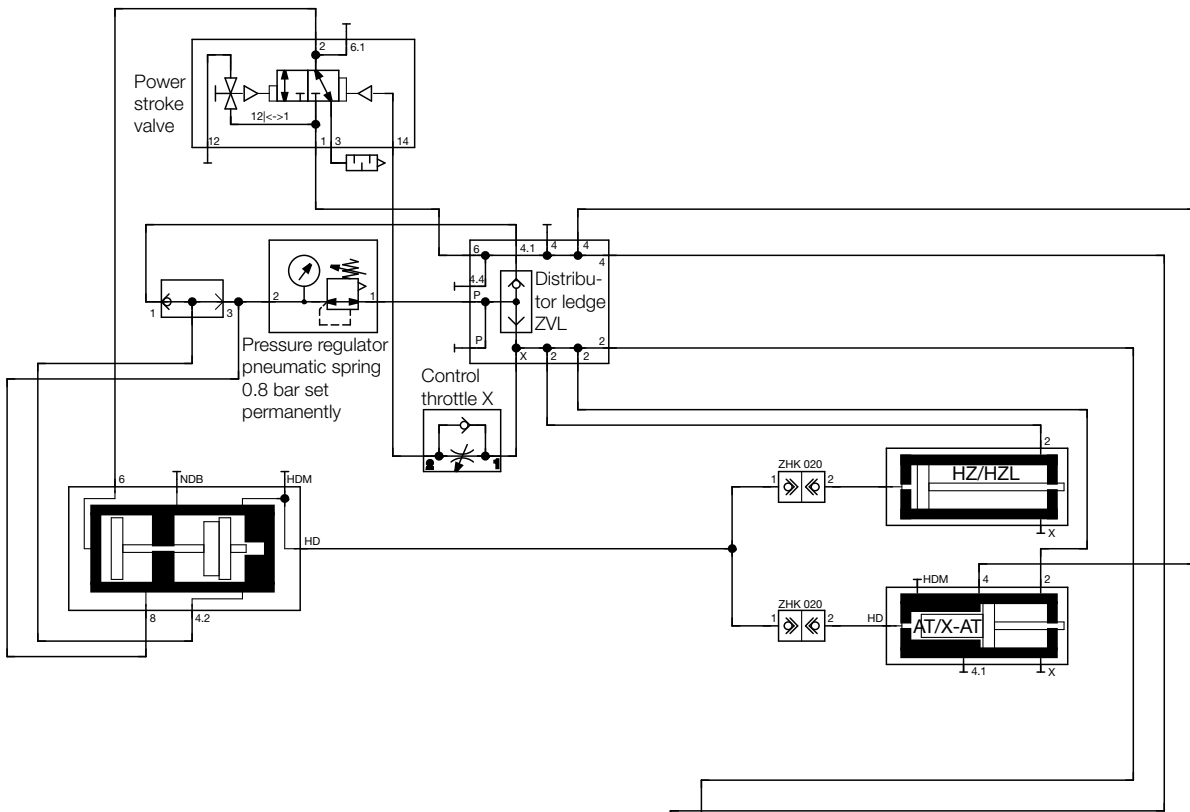

Not included in the scope of delivery!
Maintenance unit required!
Configuration range:
min. 2 bar, max. 10 bar

Control system for X-KT systems for 1-2 X-AT/HZL with power stroke valve, fast approach stroke support and control throttle X.

Description:
Storage piston during fast approach pressurized with fast approach pressure.
Storage piston during return stroke pressurized with reduced air spring pressure.
Power stroke piston permanently pressurized with reduced air spring pressure.

Ordering information

The following ordering example (TOX®-Pressure Intensifier with 2 TOX®-Hydraulic Cylinders HZL) shows, how to order a TOX®-Powerpackage X-KT system (either with working part X-AT or with hydraulic cylinder HZL):

Ordering data:	Example:	Quantity:
Order no. of the intensifier X-ES	X-ES 125.000.0123.48	1
Order no. of either the TOX®-Working Cylinder X-AT or the TOX®-Hydraulic Cylinder HZL	HZL 07.101.100	2
Length and variant no. of the hydraulic hose ZS	ZS 01.1000	2
Type of TOX®-Hydrosplit Coupling and mounting variant	ZHK 020.000, Mounting variant: 1	2

You will receive:

- 2 x HZL incl. hoses and hydrosplit coupling
- 1 x X-ES incl. hydrosplit coupling (manually switchable)

The TOX®-Powerpackage X-KT-System will be delivered in detached condition but completely filled with oil.

All components are ready for connection including colour-guided pneumatic plug-in-system.

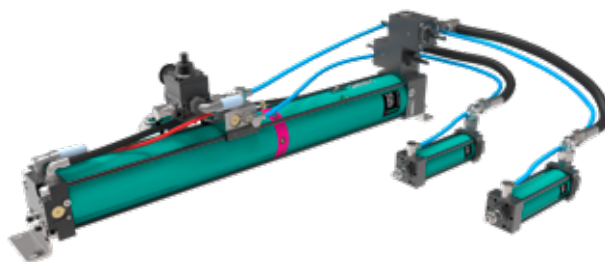

TOX[®]-Powerpackage special versions

TOX[®]-Powerpackage ZLM for use in the food industry

With the exception of line-Q, all TOX[®]-Powerpackages are available with food grade oil and grease lubrication. Both lubricants are certified according to USDA-H11 and are used wherever there is a chance of occasional, technically unavoidable contact between foodstuffs and lubricant.

TOX[®]-Powerpackages are used in industrial food manufacturing, processing, filling and packaging machines, as well as in the pharmaceutical and cosmetics industry.

Compatible with:

All TOX[®]-Powerpackages (without line-Q)

Order no.

S 1.32.6 - **ZLM**

└─── Food-grade version
└─── Order no. of TOX[®]-Powerpackage

TOX[®]-Powerpackage in anti-rust version ZRO

With the exception of line-Q, all TOX[®]-Powerpackages can be supplied with rust protection. All individual parts are either plasma nitrided, galvanised or primed and painted. These devices are particularly suitable for use in the food and packaging industries.

Compatible with:

All TOX[®]-Powerpackages (without line-Q)

Order no.

S 1.32.6 - **ZRO**

└─── Anti-rust version
└─── Order no. of TOX[®]-Powerpackage

On request, we can provide TOX[®]-Powerpackages as stainless steel version. Please contact us!